

CYBIRD
FUNE PE1 150PH

CYBIRD
FUNE PE2 150PH

CYBIRD
FUNE ST 150PH

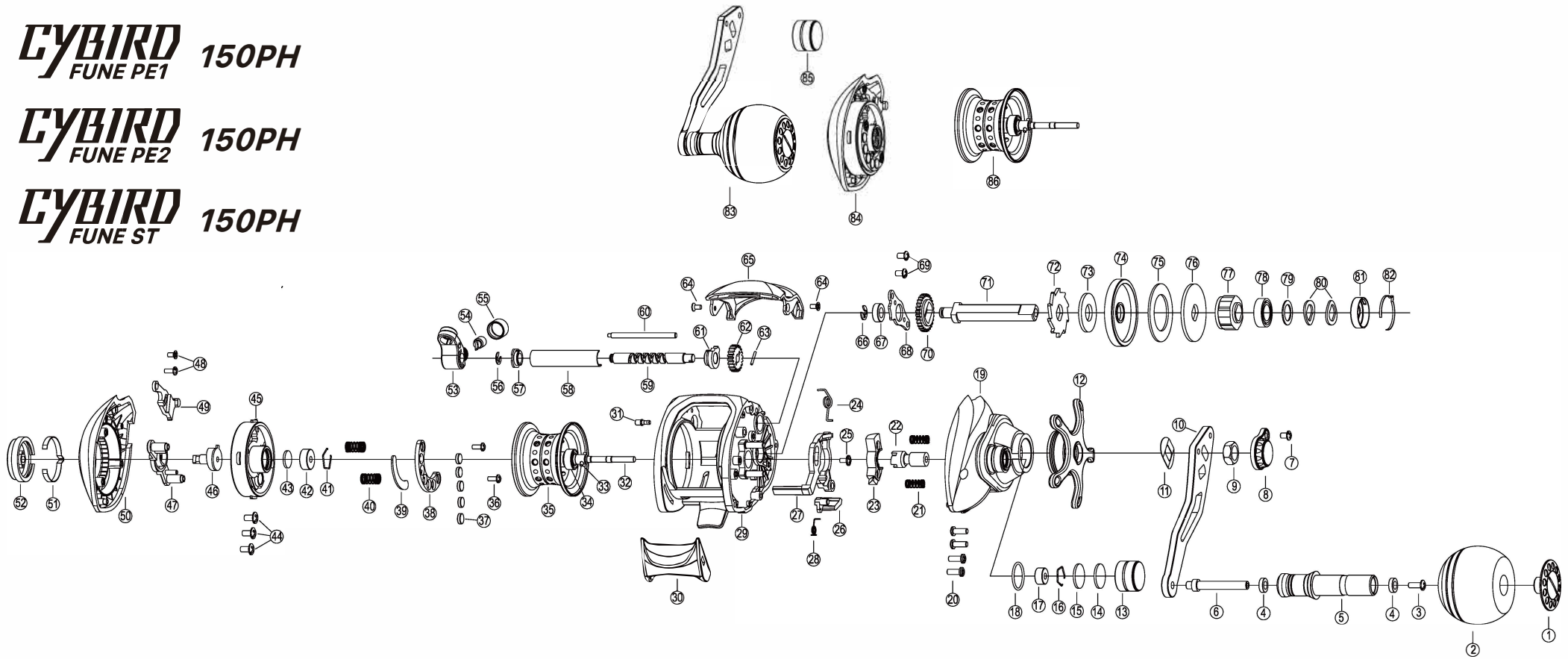

1	handle knob cap	16	stoper holder	31	left cover pin	46	brake cam	61	guide bushing-B	76	drive washer B
2	handle knob	17	bearing bush	32	spool shaft	47	brake cam plate	62	carrigage screw gear	77	one way ball bearing
3	screw	18	o-ring	33	spool shaft pin	48	screw	63	carrigage screw pin	78	ball bearing
4	bearing bush	19	right cover	34	ball bearing	49	key push lever	64	screw	79	washer
5	handle knob insert	20	screw	35	spool	50	left cover	65	front cover	80	spring washer
6	handle rivet	21	cluth spring	36	screw	51	click spring	66	e-ring	81	click holder
7	screw	22	pinion gear	37	magnet	52	brake control lever	67	bearing bush	82	click spring
8	handle nut cover	23	cluth	38	magnet holder	53	line guide holder	68	stoper plate	83	handle assy
9	handle nut	24	cluth cam spring	39	magnet plate	54	return pawl	69	screw	84	side cover assy
10	crank	25	screw	40	spring	55	pawl cap	70	connect gear	85	tension knob assy
11	crank washer	26	kick lever	41	stoper holder	56	e-ring	71	gear shaft	86	spool assy
12	star handle	27	cluth cam	42	bearing bush	57	guide bushing- A	72	ratchet		
13	control cap	28	kick lever spring	43	spool cover washer	58	stabilizer bar	73	ratchet washer		
14	cushion rubber	29	frame	44	screw	59	carrigage screw	74	drive gear		
15	brake washer	30	cluth lever	45	spool cover	60	holder guide	75	drive washer A		